

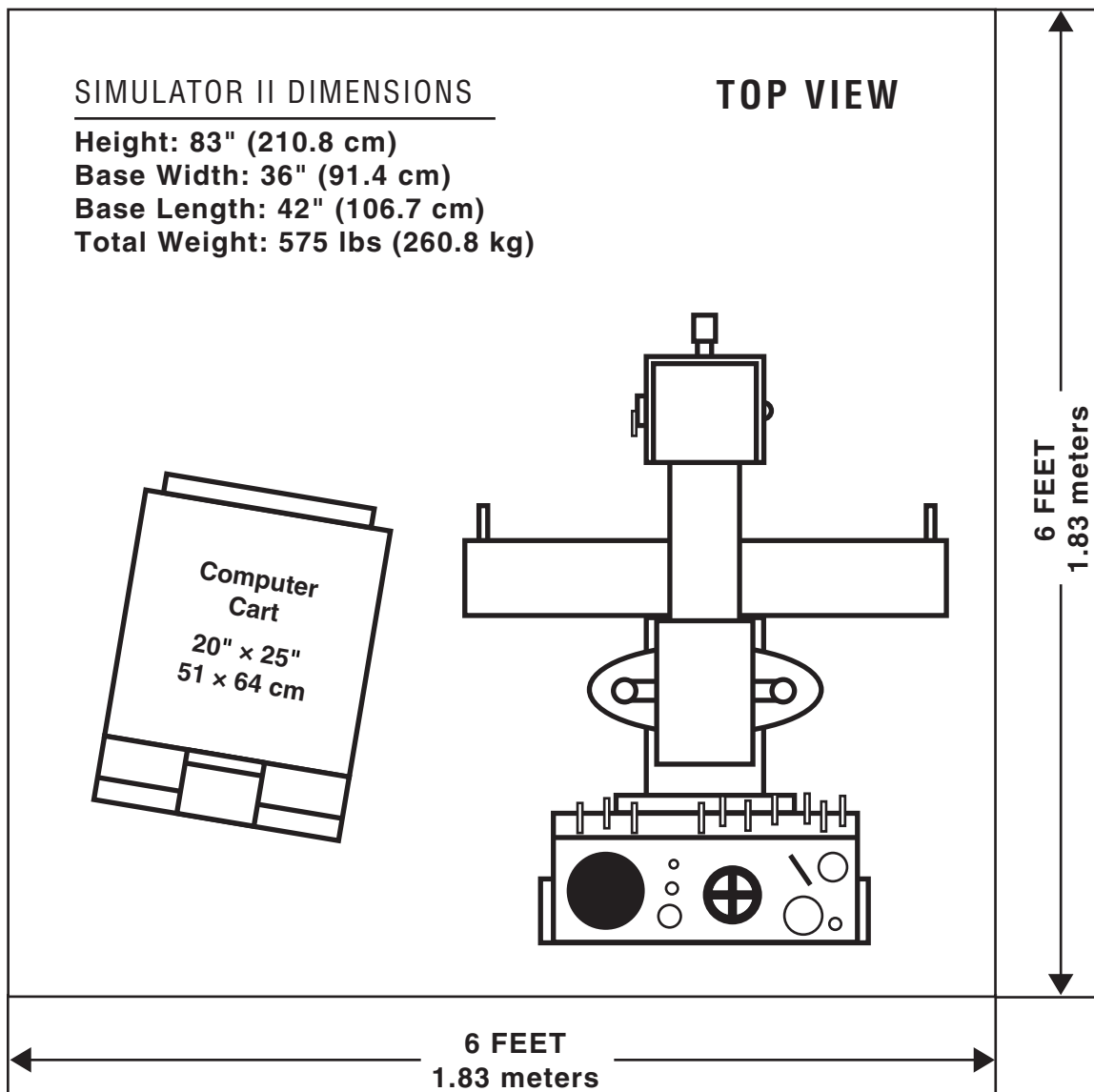

SIMULATOR II

SITE REQUIREMENT SPECIFICATIONS

Below is a layout of the minimum space requirement for the Simulator II Rehabilitation System. Note that the computer cart may be placed on either side of the Simulator.



ELECTRICAL REQUIREMENTS

US/Canada: DEDICATED 110-125 volt circuit, 60 Hz, 15 amps
International: DEDICATED 220-240 volt circuit, 50 Hz, 7.5 amps