

EVALTECH™

Functional Testing System

Site Requirements Specification

EvalTech Column Assembly w/ Base

Height: 84" (213 cm)
 Width: 47" (119 cm)
 Length: 93" (236 cm)
 ER Column Weight: 225 lbs (102 kg)
 ER Base Weight: 275 lbs (125 kg)

EvalTech Computer Cart

Height: 62" (157 cm)
 Width: 55" (140 cm)
 Length: 34" (86 cm)
 Weight: 200 lbs (91 kg)

Note that the UTM is 52" (132 cm) wide, which is wider than the base.

Allow for 18" (46 cm) around the perimeter of the system as well as between the base and computer stand.

The computer stand must be placed to the right of the column due to the tool holders.

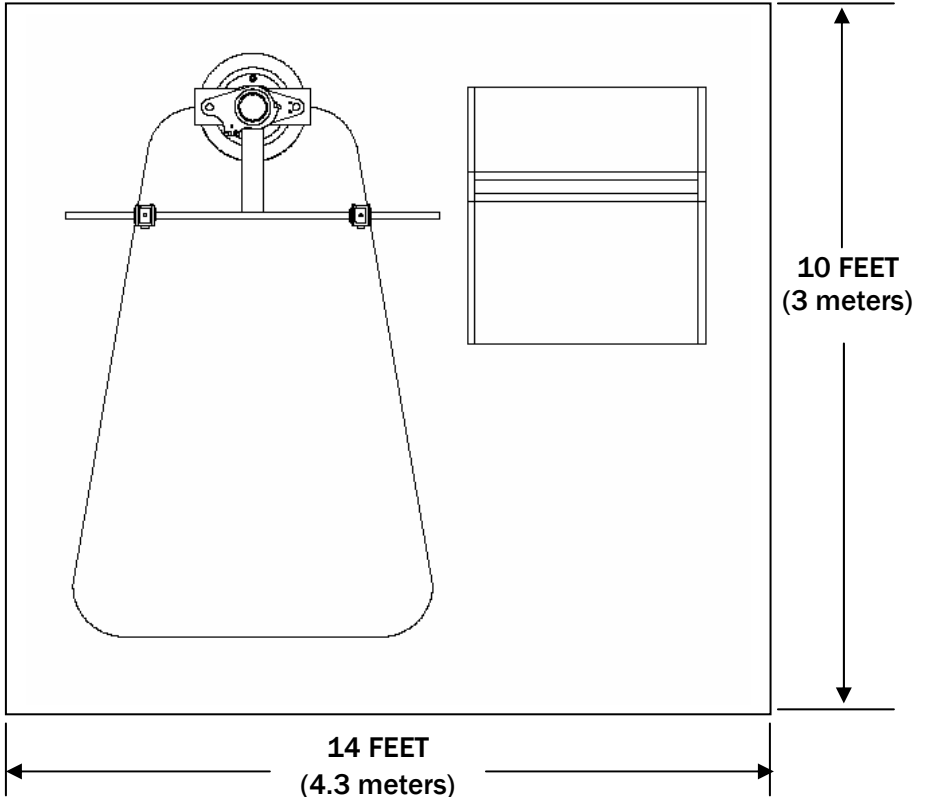

FROM

Height: 90" (229 cm)
 Width: 52" (132 cm)
 Length: 33" (84 cm)
 Weight: 150 lbs (68 kg)

The placement of the FROM with respect to the ER column and computer stand is at the discretion of the customer.

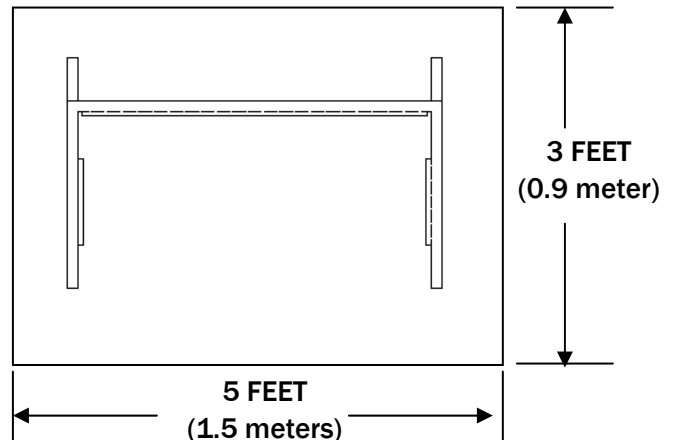

Electrical Requirements

Dedicated Circuit
 US/Canada: 110-120 Volts, 50-60 Hz, 14 Amps
 International: 220-240 Volts, 50-60 Hz, 7 Amps